

MECBO



AUT 51

TRUCK MOUNTED PUMP

Truck	4 axes
Distributor boom	AZ-50.5/125-XB3L
Pumping group	P6 / P7 / P8



PULSAR SYSTEM

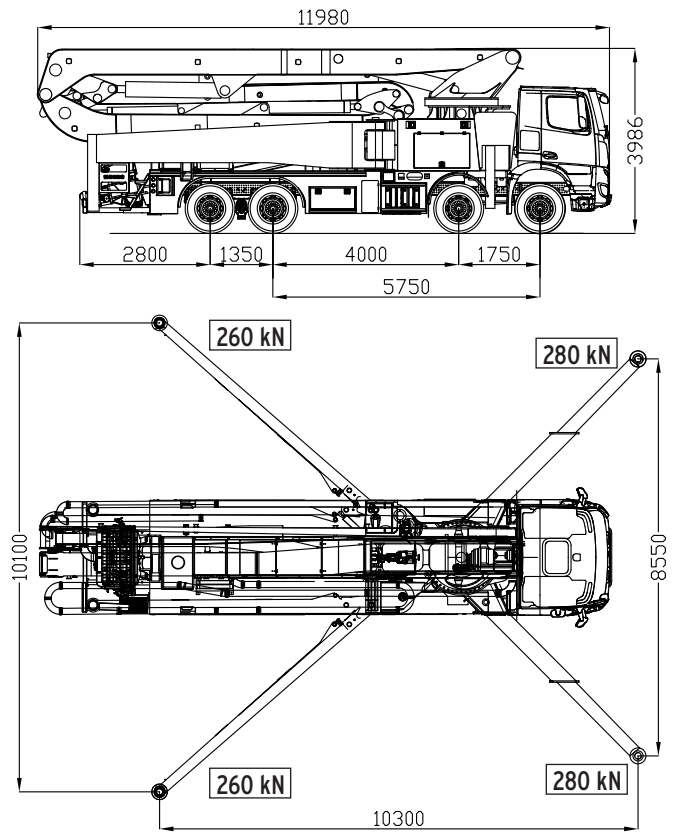
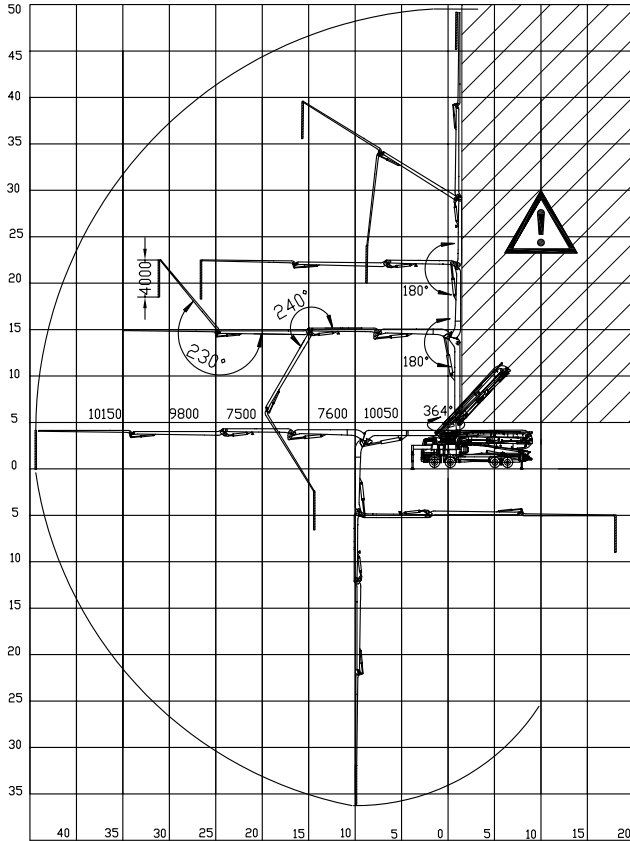

BRACCIO DISTRIBUTORE DISTRIBUTOR BOOM FLECHE DISTRIBUTEUR VERTEILERMAST

GRUPPO POMPANTE PUMPING GROUP GROUPE DE POMPAGE PUMPENGRUPPE

Diametro tubazione Pipeline diameter Diamètre de la tuyauterie Forderleitung Durchmesser	125 mm	Pompa tipo Pump type Pompe type Pumpeart	P6.110	P7.150	P8.180
Raggio orizzontale Horizontal reach Portée horizontale Horizontalablenkung	45,5 m	Diametro dei cilindri Cylinders diameter Diamètre cylindres Zylindersdurchmesser	200 mm	230 mm	250 mm
Altezza massima Max. vertical reach Portée verticale Max. Höhe	50,5 m	Corsa Stroke Course Schlaganfall	2000 mm	2000 mm	2000 mm
Min. altezza apertura Min. openig height Min. hauteur d'ouverture Min. Öffnungshöhe	11 m	Diametro uscita Outlet diameter Diamètre sortie Austrittsdurchmesser	150 mm (6" ½)	150 mm (6" ½)	180 mm (7" ½)
Numero di sezioni Sections Number Nombre de sections Anzahl der Abschnitte	5 Z	Volume tramoggia Hopper capacity Capacité trémie Kapazität des Trichters	620 l	600 l	610 l
Rotazione torretta Slewing range Rotation de la tourelle Turmdrehung	364°	Pressione in uscita Outlet pressure Pression sortie Betondruck	70 bar	70 bar	70 bar
Pressione oleodinamica Hydraulic pressure Pression hydraulique Hydraulikdruck	350 bar	Portata calcestruzzo Concrete output Débit béton Beton Fördermenge	110 m³/h	150 m³/h	180 m³/h
Tensione imp. Elettrico Electrical voltage Tension électrique Spannung des Elektr. System	12-24V	Peso gruppo pompante Pumping Group weight Poids groupe pompage Pumpegewicht	1950 kg	2300 kg	2500 kg

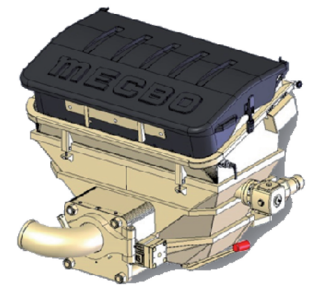

OPTIONAL – EN OPTION – FAKULTATIV

VIBRATORE – VIBRATOR
VIBRATEUR – VIBRATOR

SISTEMA STABILITA' "SINGLE SIDE RANGE" (EN 12001:2012)
STABILITY SYSTEM "SINGLE SIDE RANGE" (EN 12001:2012)
SYSTEME DE STABILITE' "SINGLE SIDE RANGE" (EN 12001:2012)
STABILITÄTSSYSTEM "SINGLE SIDE RANGE" (EN 12001:2012)

TUBAZIONE E ACCESSORI
PIPELINES AND ACCESSORIES
TUYAUTERIES ET ACCESSOIRES
ROHRLEITUNG UND ZUBEHÖRE

LUBRIFICAZIONE AUTOMATICA
LINCOLN
LINCOLN AUTOMATIC LUBRICATION
LUBRIFICATION AUTOMATIQUE
LINCOLN
AUTOMATISCHE SCHMIERUNG

Inclusi nella fornitura doppio circuito idraulico, pompa acqua, serbatoio, acqua, compressore, telecomando, radiocomando, sistema di stabilità "Full Range" (EN 12001:2012). Supplied with double hydraulic circuit, water pump and tank, air compressor, remote control by cable, wireless radio control, stability system "Full Range" (EN 12001:2012). Inclus double circuit hydraulique, pompe à eau, réservoir eau, compresseur, télécommande, radiocommande, système de stabilité "Full Range" (EN 12001:2012). Inbegriffen doppelt Hydraulikschaltung, Wasserpumpe, Wassertank, Kompressor, Kabel-Fernbedienung, Radio-Fernbedienung, Stabilitätssystem "Full Range" (EN 12001:2012).

I presenti dati tecnici hanno valore indicativo. Con l'evolversi della tecnologia, i dati esposti potranno subire modifiche senza preavviso. Le richieste tecniche specifiche debbono essere sempre accettate dalla nostra Direzione con conferma scritta. The present technical data have indicative value. Owing to the technology development, all above mentioned details may be changed without any notice. All specific technical request must be always accepted from our Management by written confirmation.