

MECBO



CITY PUMP

TRUCK MOUNTED PUMP

Truck	2 axles
Weight	12 TON
Boom	MB18.3/125
Pumping group	P4 / P6



PULSAR SYSTEM

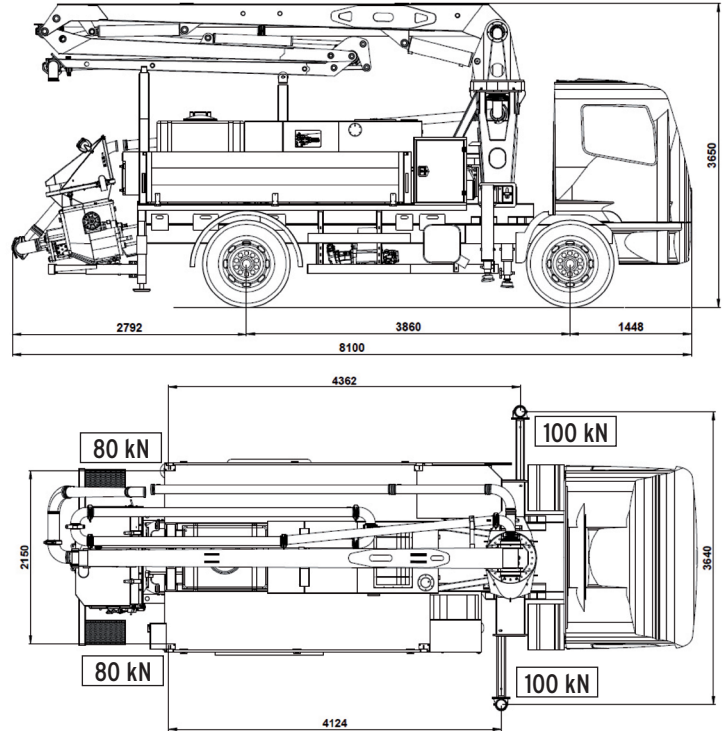
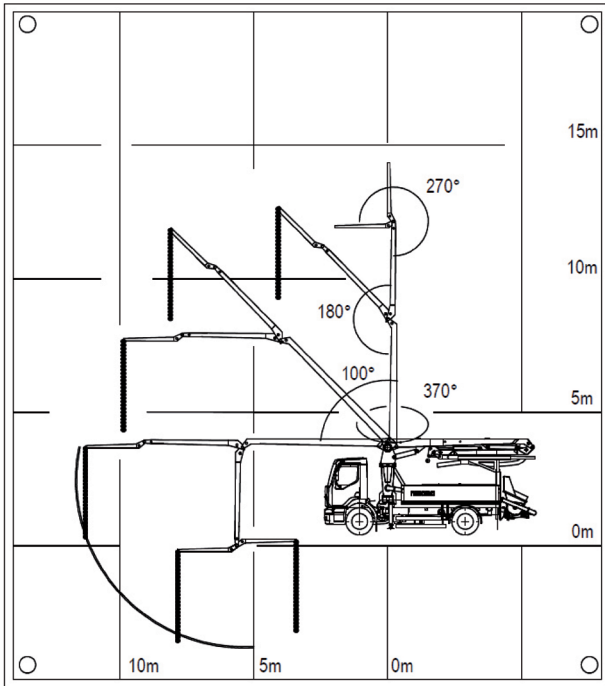

BRACCIO DISTRIBUTORE DISTRIBUTOR BOOM FLECHE DISTRIBUTEUR VERTEILERMAST		GRUPPO POMPANTE PUMPING GROUP GROUPE DE POMPAGE PUMPENGRUPPE		
Diametro tubazione Pipeline diameter Diamètre de la tuyauterie Förderleitung Durchmesser	100 mm 125 mm	Pompa tipo Pump type Pompe type Pumpentyp	P4.65	P6.90
Raggio orizzontale Horizontal reach Portée horizontale Horizontalablenkung	13 m	Diametro dei cilindri Cylinders diameter Diamètre cylindres Zylindersdurchmesser	180 mm	200 mm
Altezza massima Max. vertical reach Portée verticale Max. Höhe	17 m	Corsa Stroke Course Schlaganfall	1400 mm	1800 mm
Min. altezza apertura Min. opening height Min. hauteur d'ouverture Min. Öffnungshöhe	4 m	Diametro uscita Outlet diameter Diamètre sortie Austrittsdurchmesser	125 mm (5" 1/2)	150 mm (6" 1/2)
Numero di sezioni Sections Number Nombre de sections Anzahl der Abschnitte	3 Z	Volume tramoggia Hopper capacity Capacité trémie Kapazität des Trichters	570 l	620 l
Rotazione torretta Slewing range Rotation de la tourelle Turmdrehung	370°	Pressione in uscita Outlet pressure Pression sortie Betondruck	70 bar	70 bar
Pressione oleodinamica Hydraulic pressure Pression hydraulique Hydraulikdruck	270 bar	Portata calcestruzzo Concrete output Débit béton Beton Fördermenge	65 m³/h	90 m³/h
Tensione imp. Elettrico Electrical voltage Tension électrique Spannung des Elektr.System	12-24V	Peso gruppo pompante Pumping Group weight Poids groupe pompage Pumpegewicht	1200 kg	1750 kg
<p><i>Inclusi nella fornitura doppio circuito idraulico, pompa acqua, serbatoio. acqua, compressore, telecomando, radiocomando, sistema di stabilità "Full Range" (EN 12001:2012).</i> <i>Supplied with double hydraulic circuit, water pump and tank, air compressor, remote control by cable, wireless radio control, stability system "Full Range" (EN 12001:2012).</i> <i>Inclus double circuit hydraulique, pompe à eau, réservoir eau, compresseur, télécommande, radiocommande, système de stabilité "Full Range" (EN 12001:2012).</i> <i>Inbegriffen doppelt Hydraulikschaltung, Wasserpumpe, Wassertank, Kompressor, Kabel-Fernbedienung, Radio-Fernbedienung, Stabilitätssystem "Full Range" (EN 12001:2012).</i></p>				

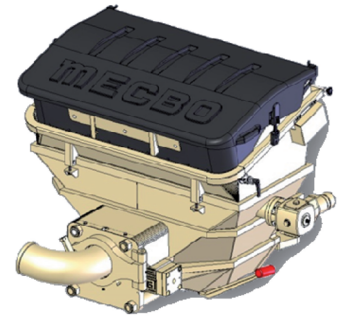

OPTIONAL – EN OPTION – FAKULTATIV

VIBRATORE – VIBRATOR
VIBRATEUR – VIBRATOR

SISTEMA STABILITA' "SINGLE SIDE RANGE" (EN 12001:2012)
STABILITY SYSTEM "SINGLE SIDE RANGE" (EN 12001:2012)
SYSTEME DE STABILITE' "SINGLE SIDE RANGE" (EN 12001:2012)
STABILITÄTSSYSTEM "SINGLE SIDE RANGE" (EN 12001:2012)

TUBAZIONE E ACCESSORI
PIPELINES AND ACCESSORIES
TUYAUTERIES ET ACCESSOIRES
ROHRLEITUNG UND ZUBEHÖRE

LUBRIFICAZIONE AUTOMATICA LINCOLN
LINCOLN AUTOMATIC LUBRICATION
LUBRIFICATION AUTOMATIQUE LINCOLN
AUTOMATISCHE SCHMIERUNG

I presenti dati tecnici hanno valore indicativo. Con l'evolversi della tecnologia, i dati esposti potranno subire modifiche senza preavviso. Le richieste tecniche specifiche debbono essere sempre accettate dalla nostra Direzione con conferma scritta. The present technical data have indicative value. Owing to the technology development, all above mentioned details may be changed without any notice. All specific technical request must be always accepted from our Management by written confirmation.