

# HYDRAULIC CRUSHERS & GRABS



WHERE **EXPERIENCE COUNTS**

# FMP SERIES -SMALL-

## FRD MULTI-PURPOSE GRAB SMALL

Multi-purpose grab for variable use and handling of different materials, as for example:

- Stone laying
- Sorting and handling of construction waste
- Sorting and handling of recycling material
- Excavation and loading of rough bulk material
- Loading of horticulture waste

## DESIGN FEATURES

- Hydraulic rotator unit with heavy duty axial and radial bearings with compact rotator
- Flat compact design. Hydraulic cylinders and ganging guidance completely protected inside the frame
- FMP20-PL and FMP30-PL cylinders with limit damping
- FMP10, FMP20-PL and FMP30-PL with load holding valve at the cylinders. It prevent the unintentional opening of the grab
- Integrated mechanical opening and closing stoppers
- Wear-resistant bottom teeth and side plates of high strength fine-grain steel ( 400 HB )
- FMP05-PL and FMP10-PL with bolt-on exchangeable teeth / FMP20-PL and FMP30-PL with ESCO-plug-in exchangeable teeth
- Grab design for free oscillating use available



		FMP05-PL	FMP10-PL	FMP15-PL	FMP20-PL	FMP30-PL
Operating weight <sup>1)</sup>	kg	152	195	320	450	830
Capacity	l	37	50	90	120	270
Sustainability max.	t	1	1	1,5	2	4
Sust.- Rot. max.	t	5	5	5	10	15
Dimension A	mm	670	705	890	1025	1210
Dimension B	mm	725	730	905	1085	1235
Dimension C	mm	610	610	800	905	1145
Dimension D	mm	900	970	1325	1530	1935
Width E	mm	360	400	450	500	660
Number of teeth	Qty	3	3	3	5	5
Closing max.	kN	19	19	28	34	56
Oper. pressure max.	Mpa	25	25	32	30	30
Oil flow max.	l/min	22	22	32	40	60
Oper. pressure max.	Mpa	25	25	25	25	25
Oil flow rotator max.	l/min	20	20	20	28	48
Base machine weight	t	1 - 2	2 - 5	4 - 7	5 - 9	9 - 15

Specifications subject to change without notice. <sup>1)</sup> Operating Weight basic unit without turning unit and mounting plate.

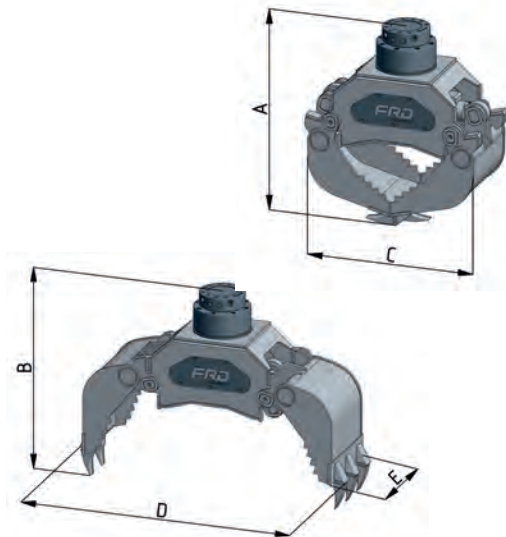

WHERE EXPERIENCE COUNTS

# FMP SERIES -LARGE-

## FRD MULTI-PURPOSE GRAB LARGE - FMP SERIE -

Multi-purpose grab for variable use and handling of different materials, as for example:

- Stone laying
- Sorting and handling of construction waste
- Sorting and handling of recycling material
- Excavation and loading of rough bulk material
- Loading of horticulture waste

## DESIGN FEATURES

- Hydraulic rotator unit with heavy duty axial and radial bearings with rotating annulus rotator
- Flat compact design. Hydraulic cylinders and ganging guidance cpl. protected inside the frame
- Cylinders with limit damping
- Load holding valve at the cylinders prevent the unintentional opening of the grab
- Integrated mechanical opening and closing stoppers
- Wear resistant bottom teeth and side plates of high strength fine-grain steel ( 400 HB )
- With ESCO-plug-in exchangeable teeth
- Grab design for free oscillating use available

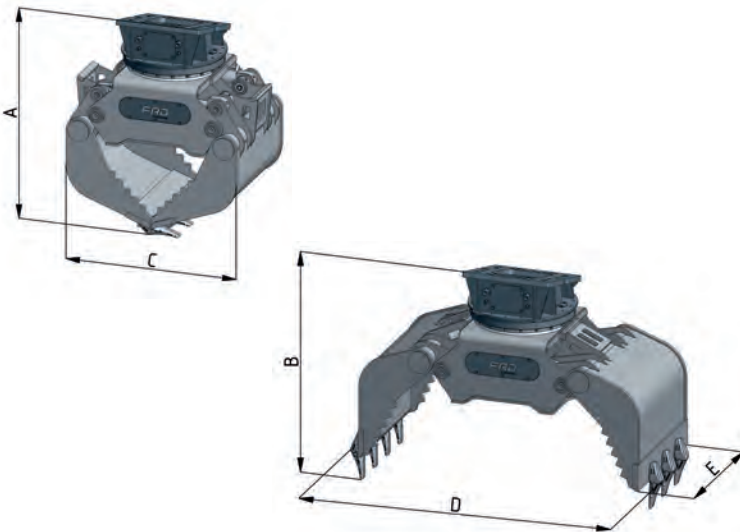

		FMP35-PL	FMP40-PL	FMP50-PL	FMP60-PL
Operating weight <sup>1)</sup>	kg	970	1665	1770	2200
Capacity	l	270	610	670	1025
Sustainability max.	t	4	6	6	8
Sust.- Rotary Engine max.	t	15	20	20	30
Dimension A	mm	1425	1630	1630	1940
Dimension B	mm	1450	1640	1640	1870
Dimension C	mm	1145	1330	1330	1500
Dimension D	mm	1935	2270	2270	2690
Width E	mm	660	940	1000	1030
Number of teeth	Stck.	5	7	7	7
Closing max.	kN	56	82	128	121
Operating pressure max.	Mpa	30	35	35	35
Oil flow max.	l/min	60	62	90	112
Operating pressure max.	Mpa	14	14	14	14
Oil flow rotator max.	l/min	30	30	30	30
Base machine weight	t	15 -20	16 - 22	23 - 30	29 - 40

Specifications subject to change without notice. <sup>1)</sup> Operating Weight basic unit without turning unit and mounting plate.

WHERE EXPERIENCE COUNTS

# DEALER NETWORK

## LOCAL SERVICE AND SUPPORT

FRD seeks firstly to supply a product of undoubted integrity. Then back this up with a support network of dedicated Distributors to ensure whatever support, wherever and whenever needed. The FRD-Distributor combination has been made unbeatable.

FRD Distributors have been selected for their professional competence, their market coverage, their dedication to quality and their willingness to work. They receive intense training on all machines and systems and every support that a committed manufacturer can give them. They actively exchange experience between each other to ensure their clients get the latest lessons from the market. They are a skilled and fast team of professionals.

## VALUE FOR MONEY

Buying FRD products is a smart investment. Top quality for a reasonable price, with long lifetime, with low maintenance and less break-down-time. In the long term this choice makes financially better results.

Next steps? FRD Europe and its Distributors have a vast resource of information beyond what can be mentioned here. Do not hesitate to get in touch for more detail and an unbeatable quote.



WHERE **EXPERIENCE** COUNTS

**Authorized distributor:**



**Furukawa Rock Drill Europe BV**

Proostwetering 29, 3543 AB Utrecht, The Netherlands  
Phone +31-(0)30-2412277 - frd@frd.eu / www.frd.eu



WHERE **EXPERIENCE COUNTS**